

Portata - Capacity - Débit																
l/min	0	100	200	300	400	500	600	650	700	750	800	850	900	950	1000	1100
l/s	0	1,6	3,3	5	6,6	8,3	10	10,8	11,7	12,5	13,3	14,2	15	15,8	16,6	18,3
m³/h	0	6	12	18	24	30	36	39	42	45	48	51	54	57	60	66

Prevalenza manometrica totale in m - Total manometric head in m - Hauteur manométrique totale en m																
m	32,9	31	29,4	28	26,8	25,8	24,8	24,2	23,8	23,2	22,8	22	21,5	20,9	20,1	18,8

Q-H= UNI EN ISO 9906
 ▲ Rischio sedimentazione - Sedimentation risk - Risque de sédimentation
 ▼ Funzionamento intermittente - Intermittent running - Fonctionnement intermittent
 Le curve si riferiscono a liquidi con densità 1 kg/dm³, con velocità non inferiore a 1 m/s e viscosità pari a quella dell'acqua.
 Curves established for liquids density 1kg/dm³, with velocity not less than 1m/s and same viscosity as water.
 Courbes établies pour liquides densité 1kg/dm³, vitesse mini. 1m/s, même viscosité de l'eau.

DATI POMPA - PUMP DATA - DONNEES DE LA POMPE			
		50 Hz	60 Hz
Ø Girante Ø Impeller Ø Roue	[mm] [mm] [mm]	153	134
Altezza pala girante Impeller blade height Hauteur palette de roue	[mm] [mm] [mm]	-	-
Ø Passaggio libero Ø Free passage Ø Passage intégral	[mm] [mm] [mm]	50	50
Peso Weight Poids	[kg] [kg] [kg]	70	70

DATI MOTORE - MOTOR DATA - DONNEES DU MOTEUR			
		50 Hz	60 Hz
PN	Potenza nominale [kW] Rated power [kW] Puisissance nominale [kW]	5,5	5,5
P1	Potenza assorbita in rete [kW] Network absorbed power [kW] Puisissance absorbée [kW]	6,5	6,5
P2	Potenza all'asse [kW] Power at the motor shaft [kW] Puisissance utile [kW]	5,4	5,4
η	Rendimento idraulico [%] Hydraulic efficiency [%] Rendiment hydraulique [%]	60	60
Alimentazione Phases Alimentation		3	3
Tensione Voltage Voltage		400±10%	400±10%
Frequenza Frequency Fréquence		50	60
Giri/min RPM Tours/min		2850	3420
Poli Poles Pôles		2	2
Corrente nominale Rated current Intensité		12	12
Condensatore Capacitor Condensateur		-	-
Fattore di potenza Power factor Facteur de puissance		0,85	0,85

DIMENSIONI D'INGOMBRO - OVERALL DIMENSIONS - DIMENSIONS D'ENCOMBREMENT

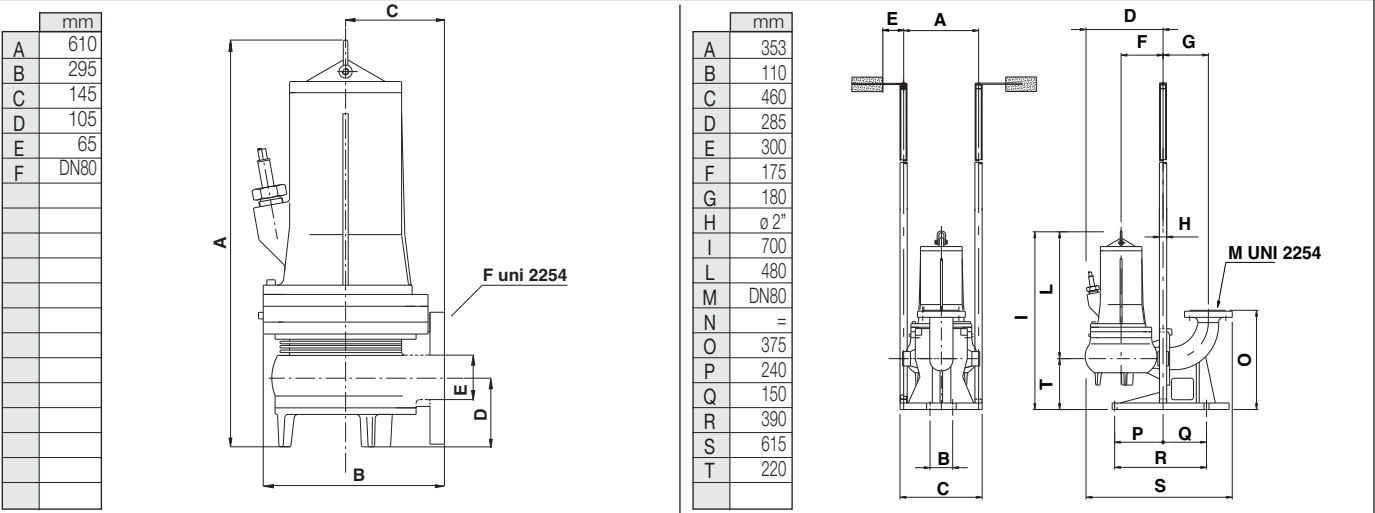

Con dispositivo di accoppiamento - With coupling foot - Avec dispositif de raccordement

Possibili aggiornamenti senza preavviso - Revision possible without prior notice - Mises à jour éventuelles sans préavis