

### DATI POMPA - PUMP DATA - DONNEES DE LA POMPE

		50 Hz	60 Hz
Ø Girante Ø Impeller Ø Roue	[mm] [mm] [mm]	146	-
Altezza pala girante Impeller blade height Hauteur palette de roue	[mm] [mm] [mm]	-	-
Ø Passaggio libero Ø Free passage Ø Passage intégral	[mm] [mm] [mm]	50	-
Peso Weight Poids	[kg] [kg] [kg]	67	-

### DATI MOTORE - MOTOR DATA - DONNEES DU MOTEUR

		50 Hz	60 Hz
PN	Potenza nominale [kW] Rated power [kW] Puissance nominale [kW]	4,4	-
P1	Potenza assorbita in rete [kW] Network absorbed power [kW] Puissance absorbée [kW]	6	-
P2	Potenza all'asse [kW] Power at the motor shaft [kW] Puissance utile [kW]	4,5	-
η	Rendimento idraulico [%] Hydraulic efficiency [%] Rendimento hydraulique [%]	55	-
Alimentazione Phases Alimentation		3	-
Tensione Voltage Voltage	[V] [V] [V]	400±10%	-
Frequenza Frequency Fréquence	[Hz] [Hz] [Hz]	50	-
Giri/min RPM Tours/min		2890	-
Poli Poles Pôles		2	-
Corrente nominale Rated current Intensité	[A] [A] [A]	11	-
Condensatore Capacitor Condensateur	[µF] [µF] [µF]	-	-
Fattore di potenza Power factor Facteur de puissance	[COSφ] [COSφ] [COSφ]	0,88	-

### Portata - Capacity - Débit

I/min	0	100	200	300	400	500	600	650	700	750	800	850	900	950	1000	1100
l/s	0	1,6	3,3	5	6,6	8,3	10	10,8	11,6	12,5	13,3	14,2	15	15,8	16,6	18,3
m³/h	0	6	12	18	24	30	36	39	42	45	48	51	54	57	60	66

### Prevalenza manometrica totale in m - Total manometric head in m - Hauteur manométrique totale en m

m	28	26,8	25,5	24,2	23	21,8	20,6	20	19,3	18,8	18	17,4	16,8	16,1	15,6	14,3
---	----	------	------	------	----	------	------	----	------	------	----	------	------	------	------	------

### DIMENSIONI D'INGOMBRO - OVERALL DIMENSIONS - DIMENSIONS D'ENCOMBREMENT

	mm
A	610
B	295
C	145
D	105
E	65
F	DN80

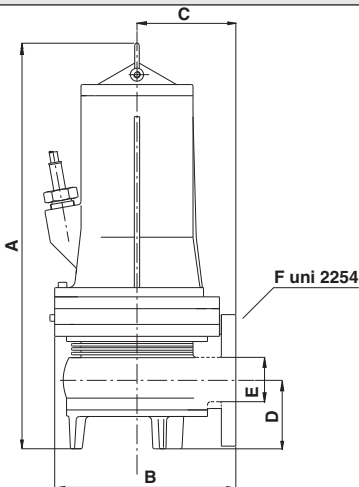

	mm
A	353
B	110
C	460
D	285
E	300
F	175
G	180
H	Ø 2"
I	700
L	480
M	DN80
N	=
O	375
P	240
Q	150
R	390
S	615
T	220

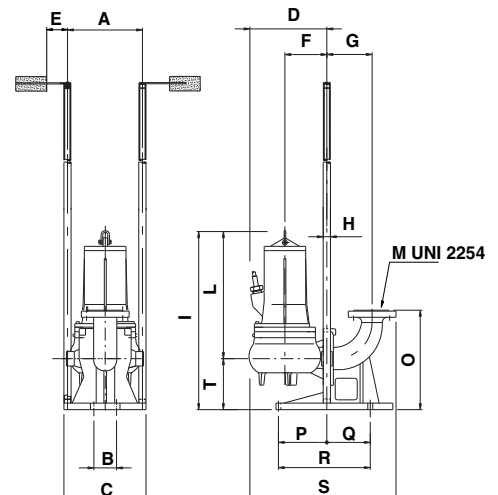

Con dispositivo di accoppiamento - With coupling foot - Avec dispositif de raccordement